

PRORIL

60Hz

Serving a wide range of slurry transport applications, STORMY-P series pumps are designed for long wear life, low energy consumption, excellent performance, and easy maintenance. With patented ACrS Tech and rugged construction, these abrasion and corrosion resistant slurry pumps provide economical solutions for challenging slurry transportation.

Slurry and Sand Pump

STORMY 6150P/6150PL

Open Stand and Agitator Pump



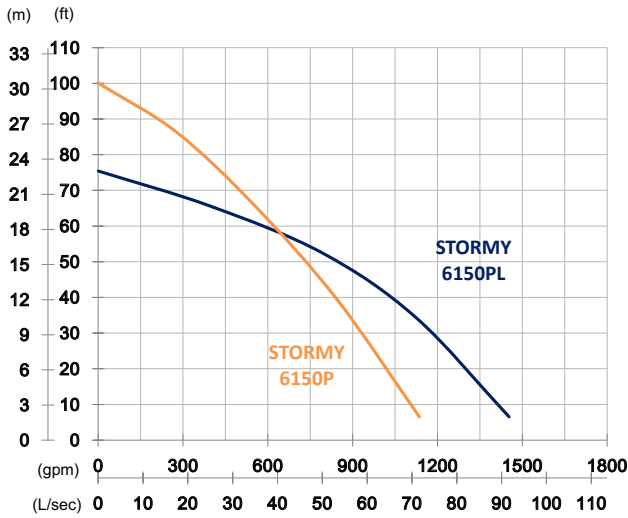

	STORMY 6150P	STORMY 6150PL
OUTPUT	20 HP (15 kW)	20 HP (15 kW)
OUTLET	6" (150 mm)	6" (150 mm)
SOLID PASSAGE	1.4" (35 mm)	1.4" (35 mm)
Weight	443 lbs/201 kg	443 lbs/201 kg
HEAD	Rated: 66 ft, 20 m Max: 100 ft, 30.5 m	Rated: 52 ft, 16 m Max: 75 ft, 23 m
FLOW	Rated: 555 gpm, 35 L/s Max: 1136 gpm, 71.7 L/s	Rated: 793 gpm, 50 L/s Max: 1453 gpm, 91.7 L/s

Pump Type	Electric Submersible Pumps	
Motor	Phase	3-Phase
	Type	Induction Motor
	Poles	4 Pole (1750 rpm)
	Insulation	Class F
	Protector	Circle Thermal Protector
	Starter	D.O.L.
Lubricant	Food Grade (ISO VG32)	
Specs.	Impeller Type	Opened
	Shaft Seal	Double Mechanical Seal
		Silicon Carbide VS Ceramic/Carbon
	Bearings	C3 Shielded ball bearings
Cable	CSA-Certified PVC Jacketed Cables	
	33 ft (10 m) or longer upon request	
Materials	Pump Casing	Ductile Iron
	Impeller	Chromium Iron
	Motor Frame	Gray Iron
	Motor Shaft	Stainless Steel
	Wear Plate	Chromium Iron
	Agitator	Chromium Iron
Max. Liquid Temperature	40°C (104°F)	
Max. Submersion Depth	20 m (66 ft)	
pH Range	pH 5 - pH 8	

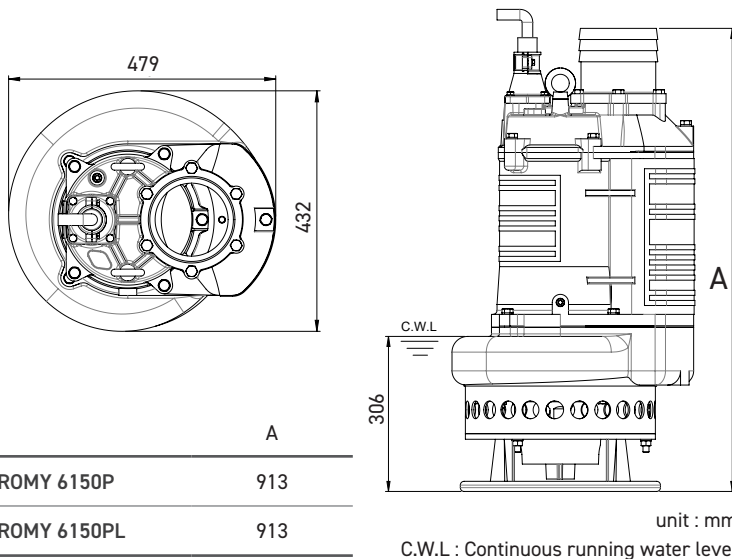

STORMY 6150P	913
STORMY 6150PL	913